

ATK Promontory Facility – Figure 6A

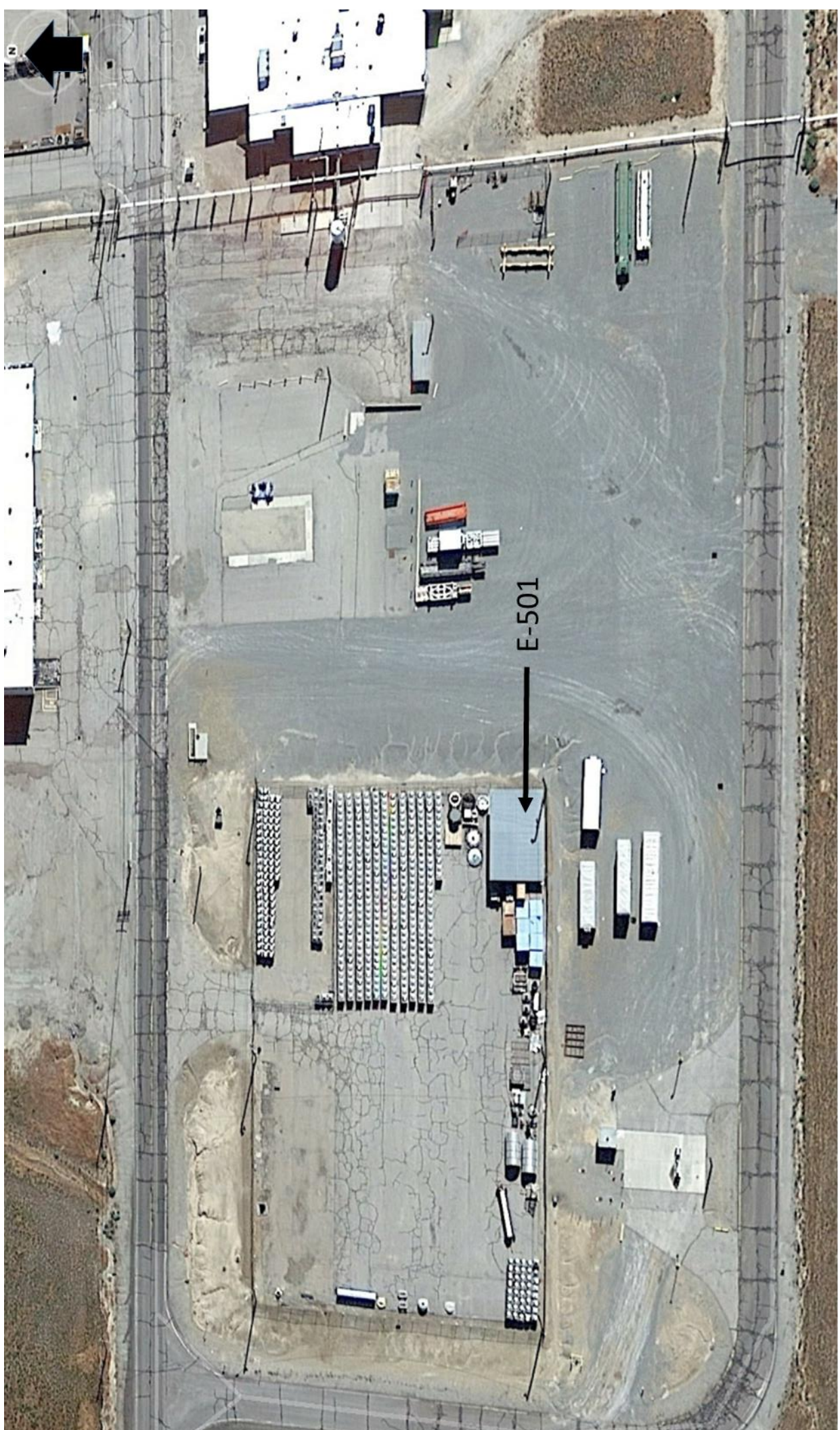
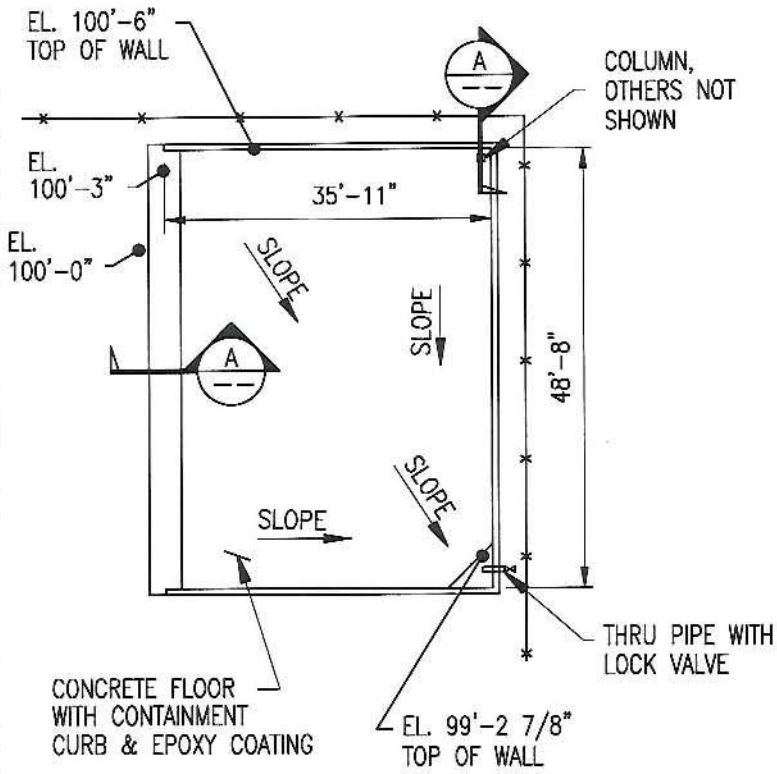
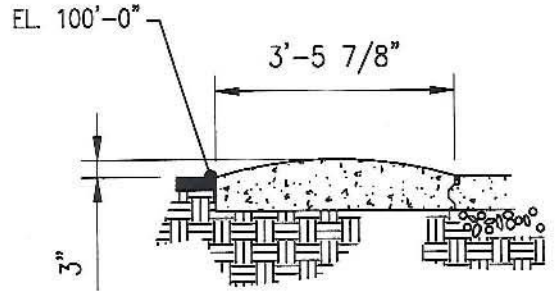


Figure 6B



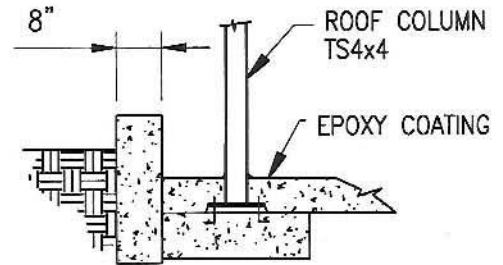
E-501 PLAN VIEW

SCALE: 1" = 20'-0"±



SECTION A

SCALE: 3/8" = 1'-0"



SECTION B

SCALE: 3/8" = 1'-0"

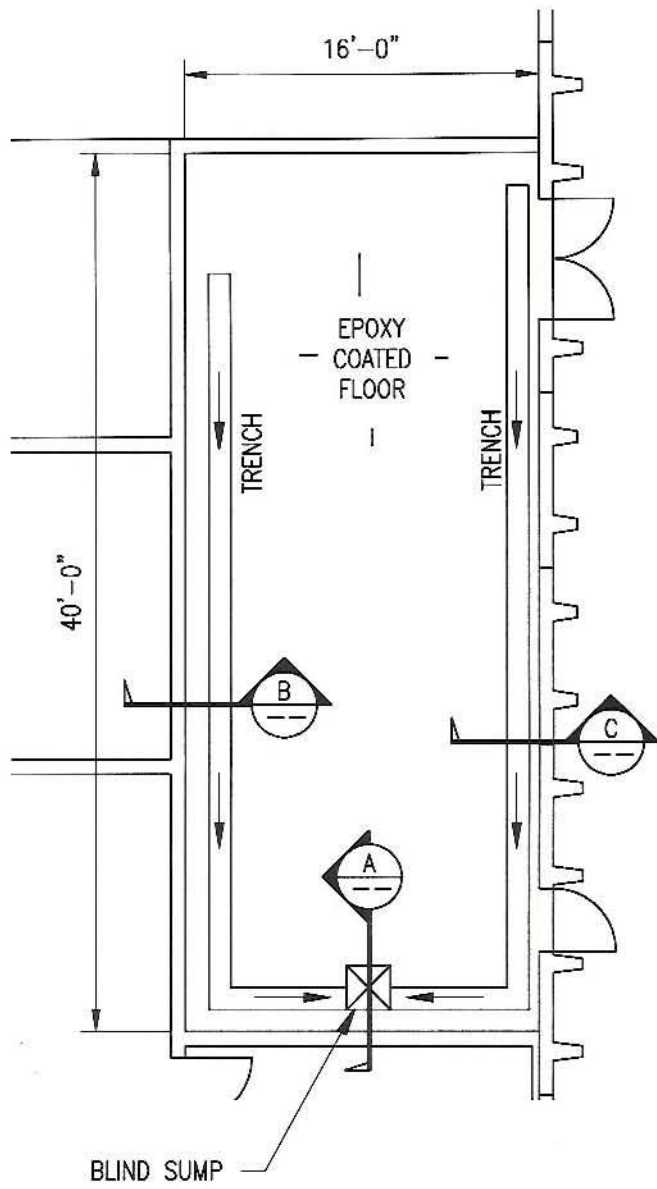
E-501 PAD LAYOUT

FIGURE B-1



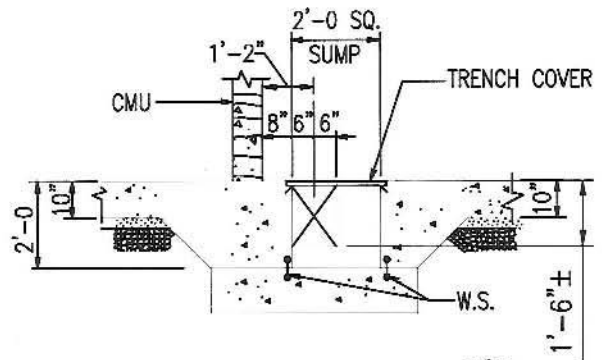


Figure 6C



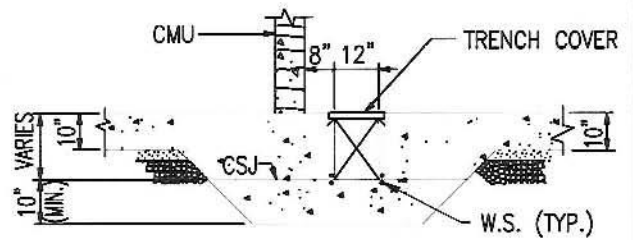
M-705S PLAN VIEW

SCALE: 1/8" = 1'-0"



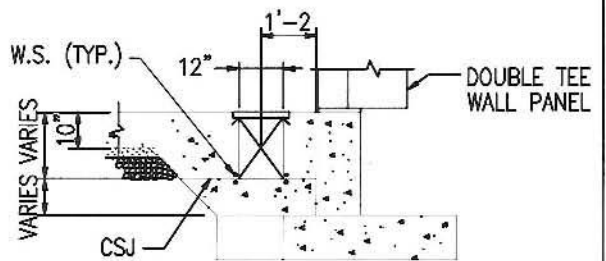
SECTION A

SCALE: 1/4" = 1'-0"



SECTION B

SCALE: 1/4" = 1'-0"



SECTION C

SCALE: 1/4" = 1'-0"

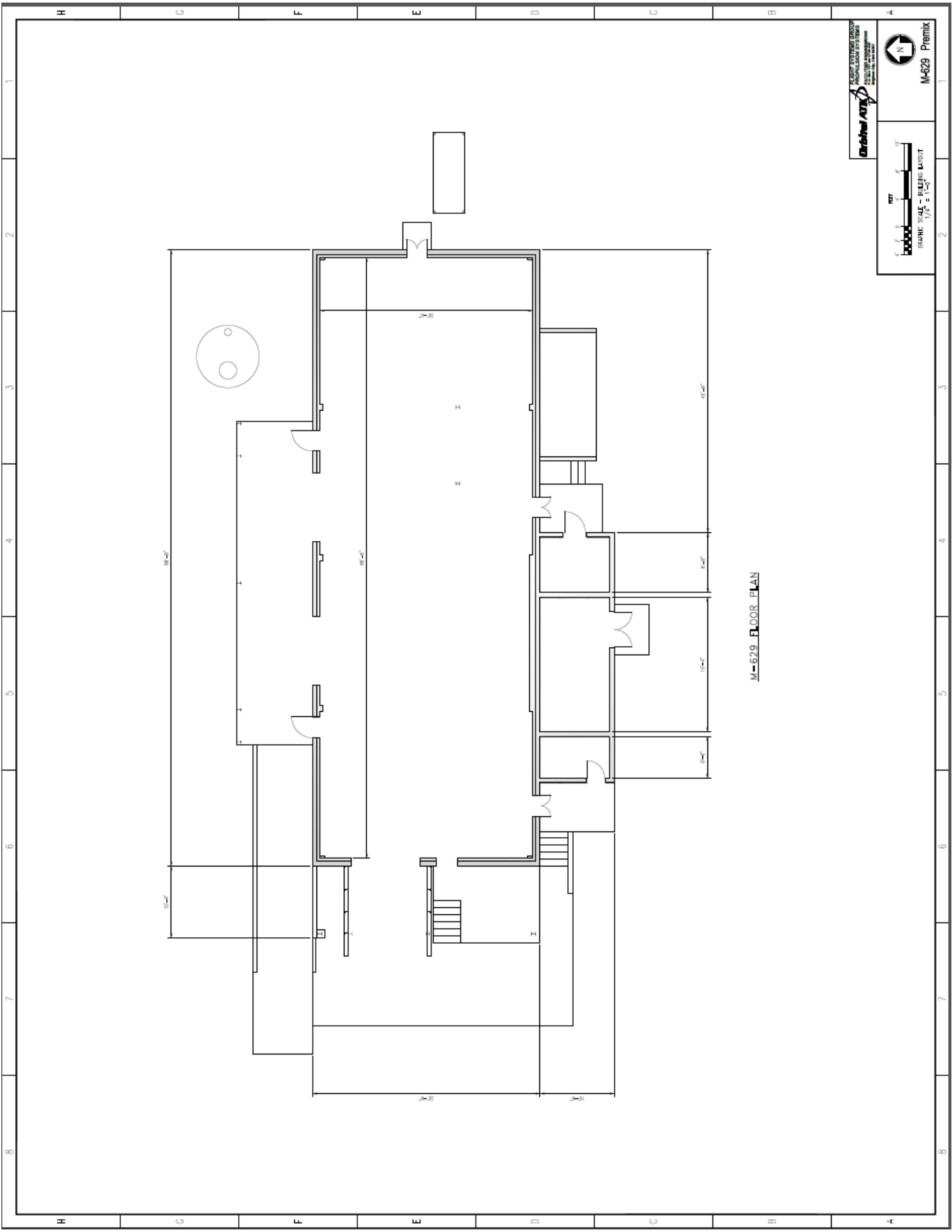
M-705S BUILDING LAYOUT

FIGURE C-1





Figure 6D



CRITCHFIELD ARCHITECTS
 ARCHITECTS
 1000 WEST 10TH AVENUE
 DENVER, CO 80202
 PHONE: 303.733.1111
 FAX: 303.733.1112
 WWW.CRITCHFIELDARCHITECTS.COM

M-629 Premix

GRAPHIC SCALE - BUILDING UNITS
 1/8" = 1'-0"

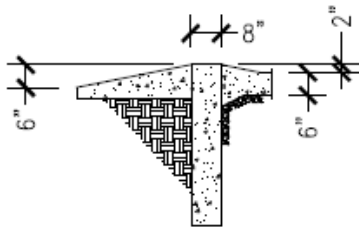
North Arrow

M-629 FLOOR PLAN

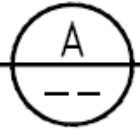


M-186

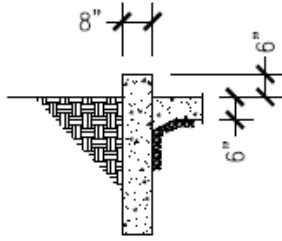
Figure 6E



SECTION



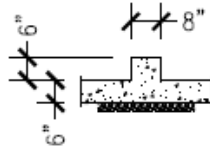
SCALE: 1/4"=1'-0"



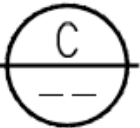
SECTION



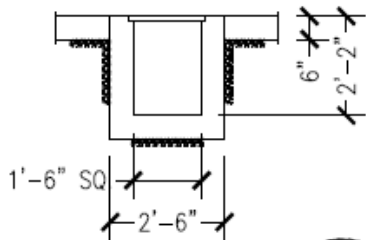
SCALE: 1/4"=1'-0"



SECTION



SCALE: 1/4"=1'-0"

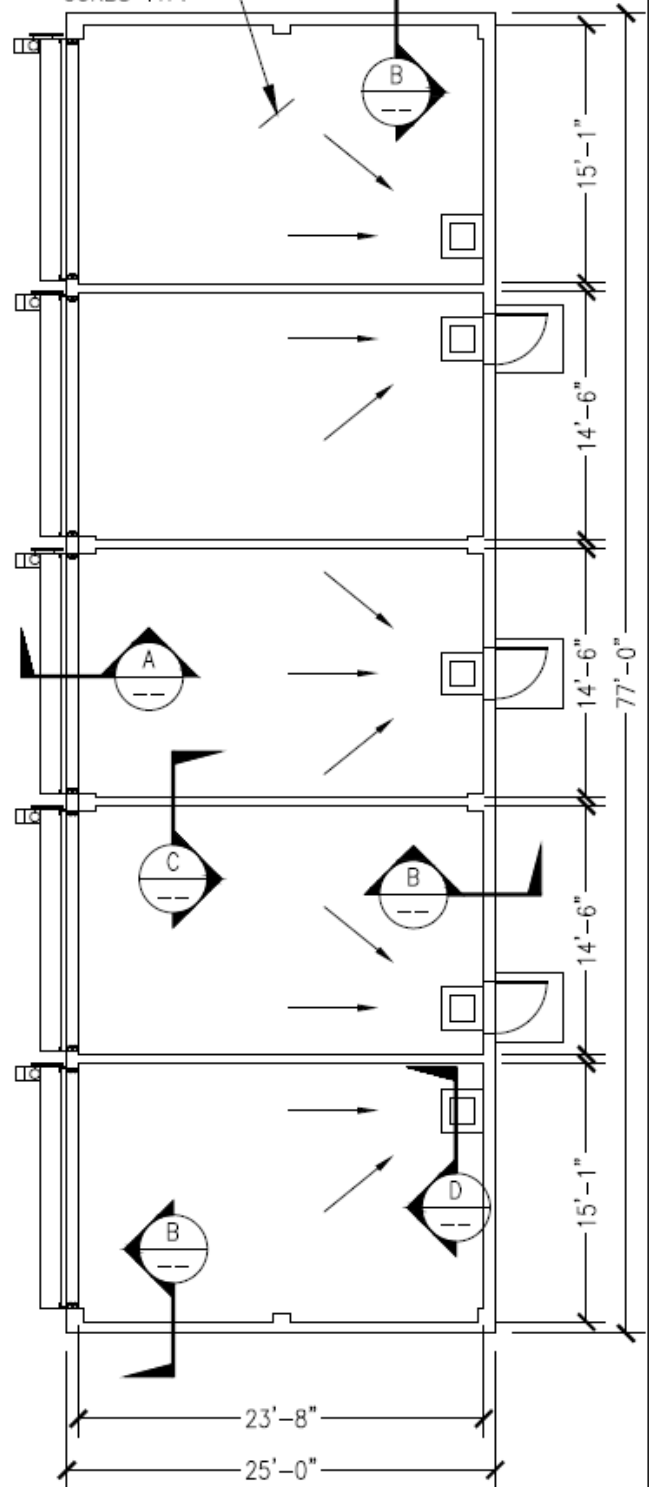


SECTION



SCALE: 1/4"=1'-0"

CHEMICAL RESISTANT
CONCRETE FLOOR
W/ CONTAINMENT
CURBS TYP.



M-186A BUILDING LAYOUT
FIGURE E-1



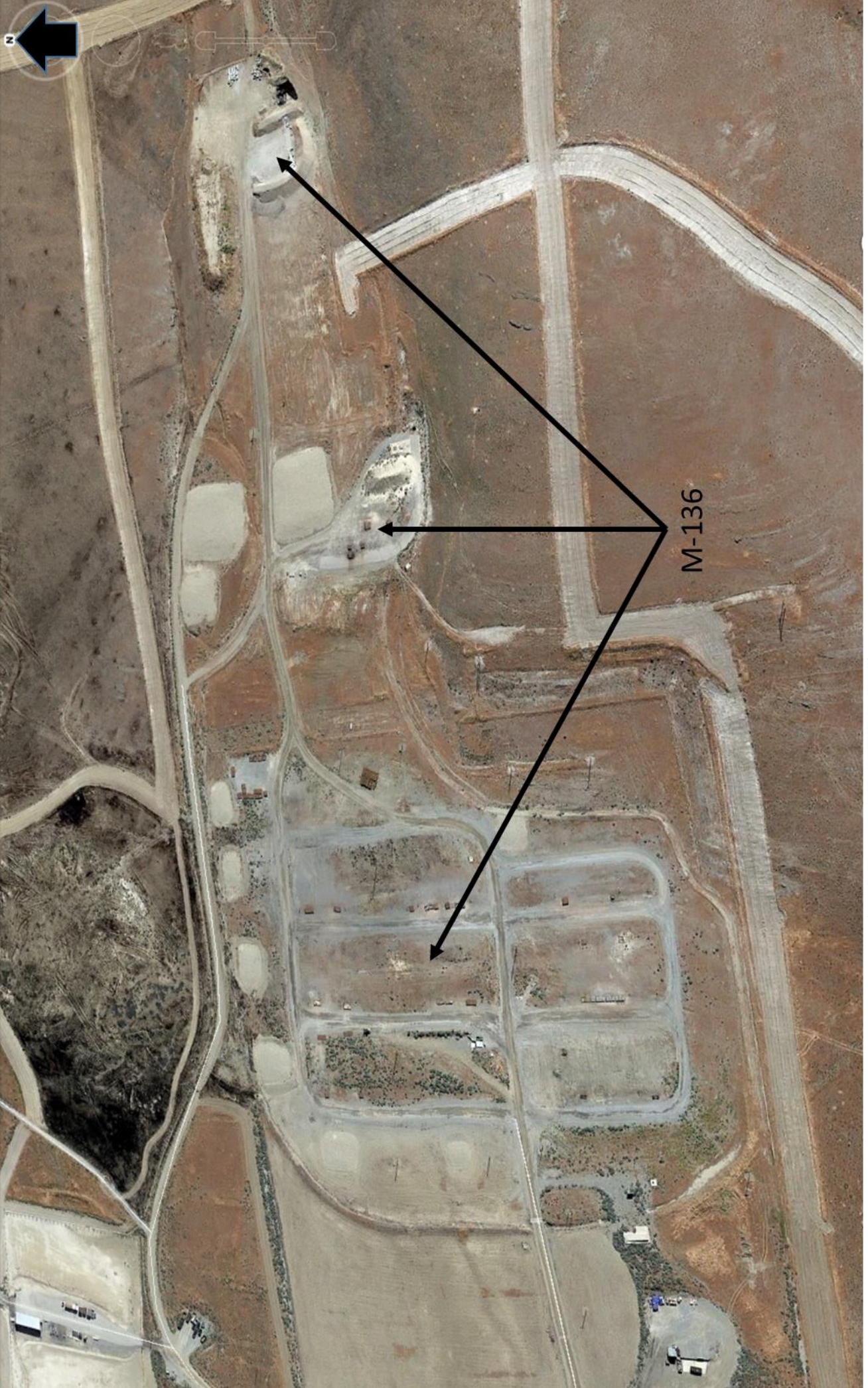
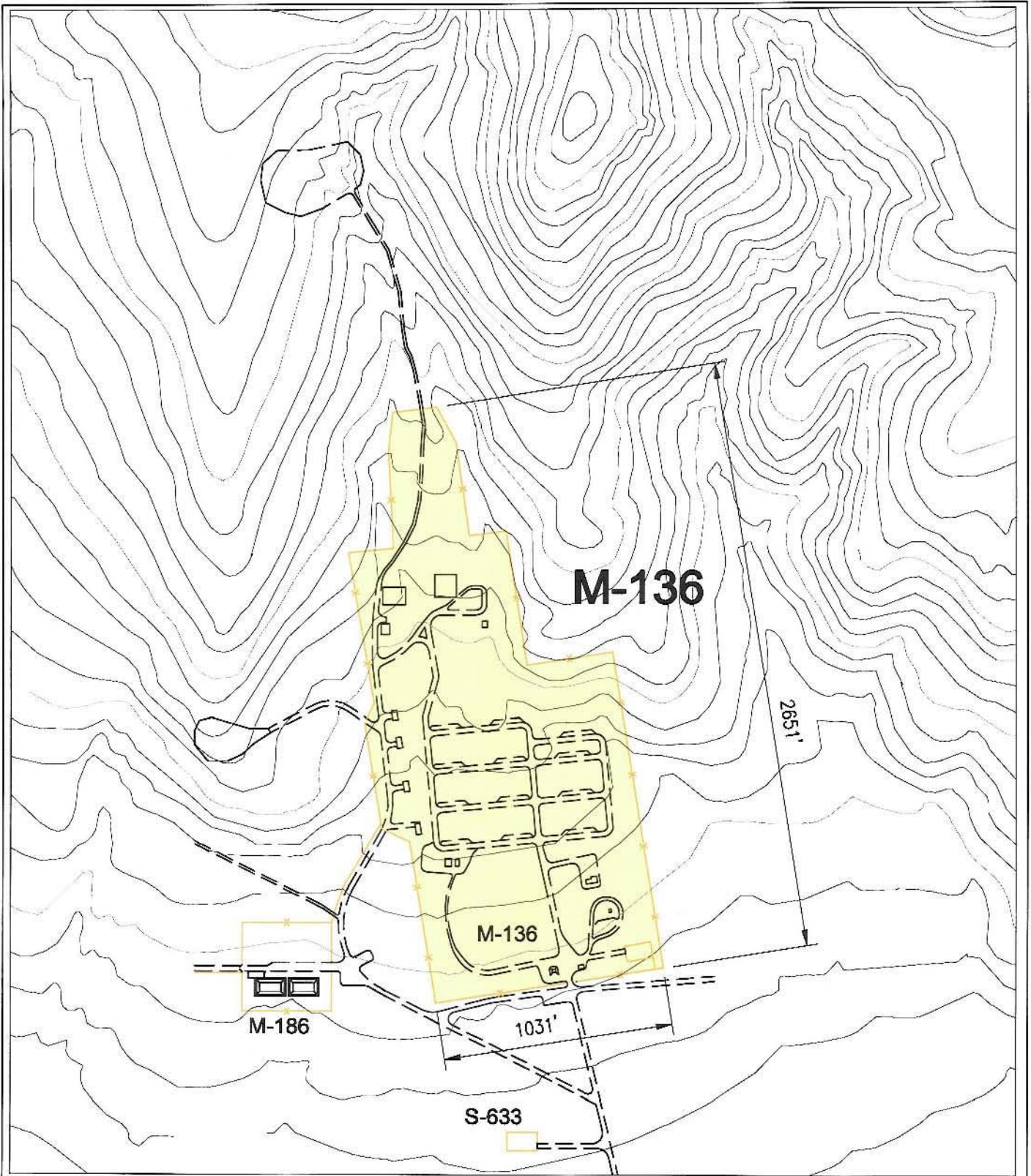


Figure 6F



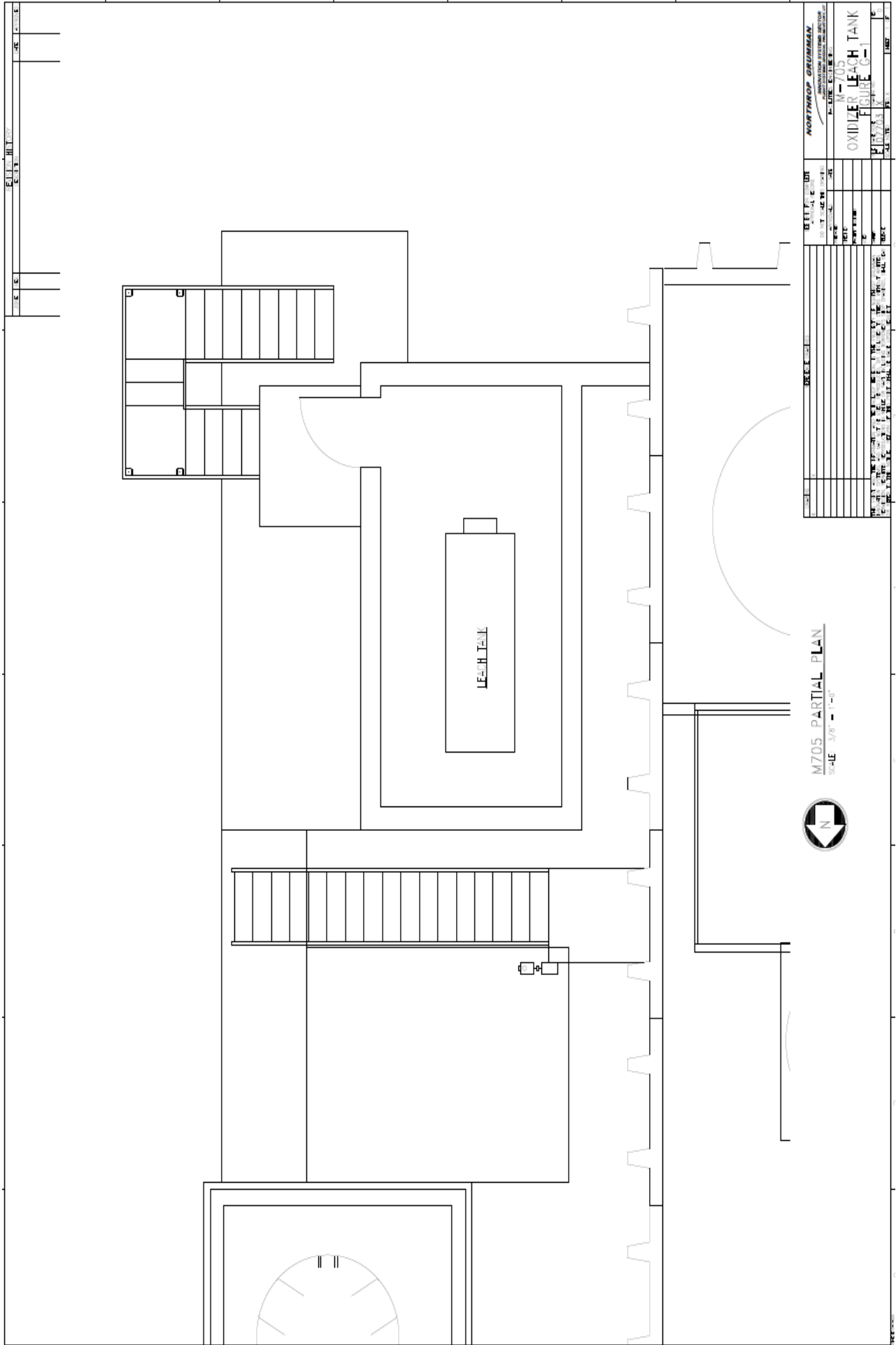
**M-136 BURN GROUND
FACILITY LAYOUT
FIGURE F-1**



SCALE: 1" = 600' - 0"±



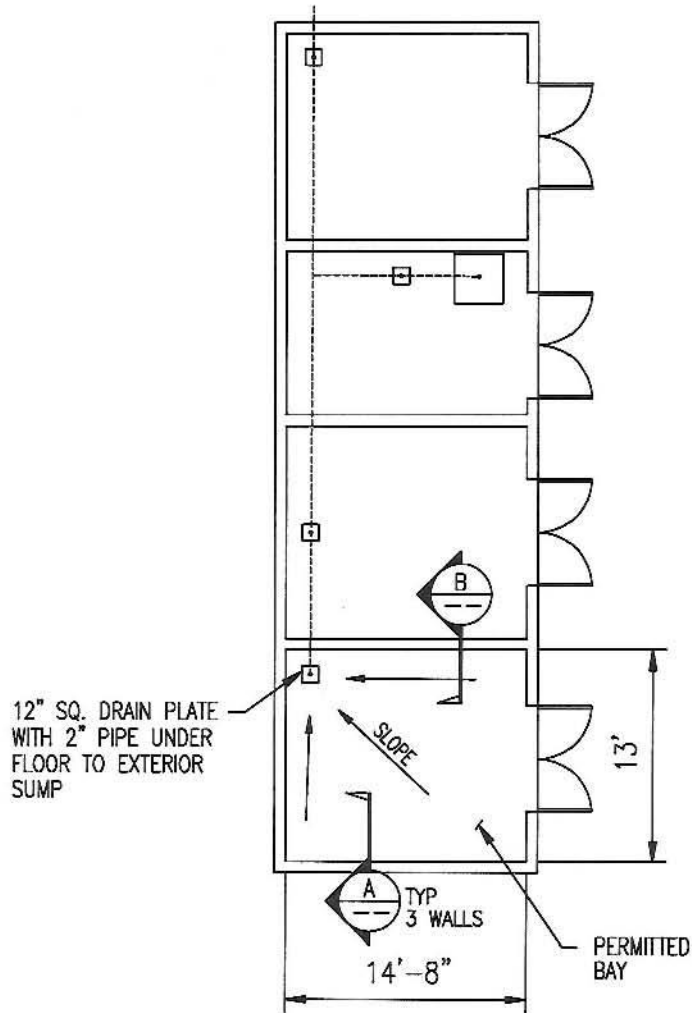
Figure 6G



PROJECT		M705 PARTIAL PLAN	
DATE	NO. OF SHEETS	NO. OF SHEETS	NO. OF SHEETS
1987	1	1	1
DESIGNER		NORTHROP GRUMMAN	
DRAWN		P. L. B. / J. S. B.	
CHECKED		M. J. B.	
APPROVED		M. J. B.	
PROJECT		OXIDIZER LEACH TANK	
LOCATION		FISHRE G-1	
DRAWN		P. L. B. / J. S. B.	
CHECKED		M. J. B.	
APPROVED		M. J. B.	

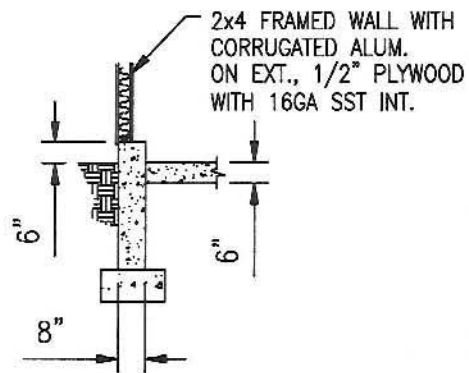


Figure 6H



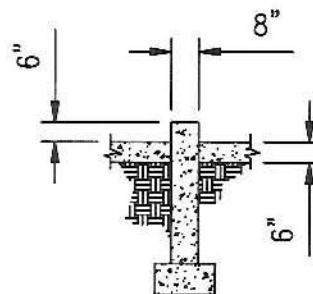
T-29B PLAN VIEW

SCALE: 1" = 10'-0"



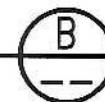
SECTION

SCALE: 1/4" = 1'-0"



SECTION

SCALE: 1/4" = 1'-0"



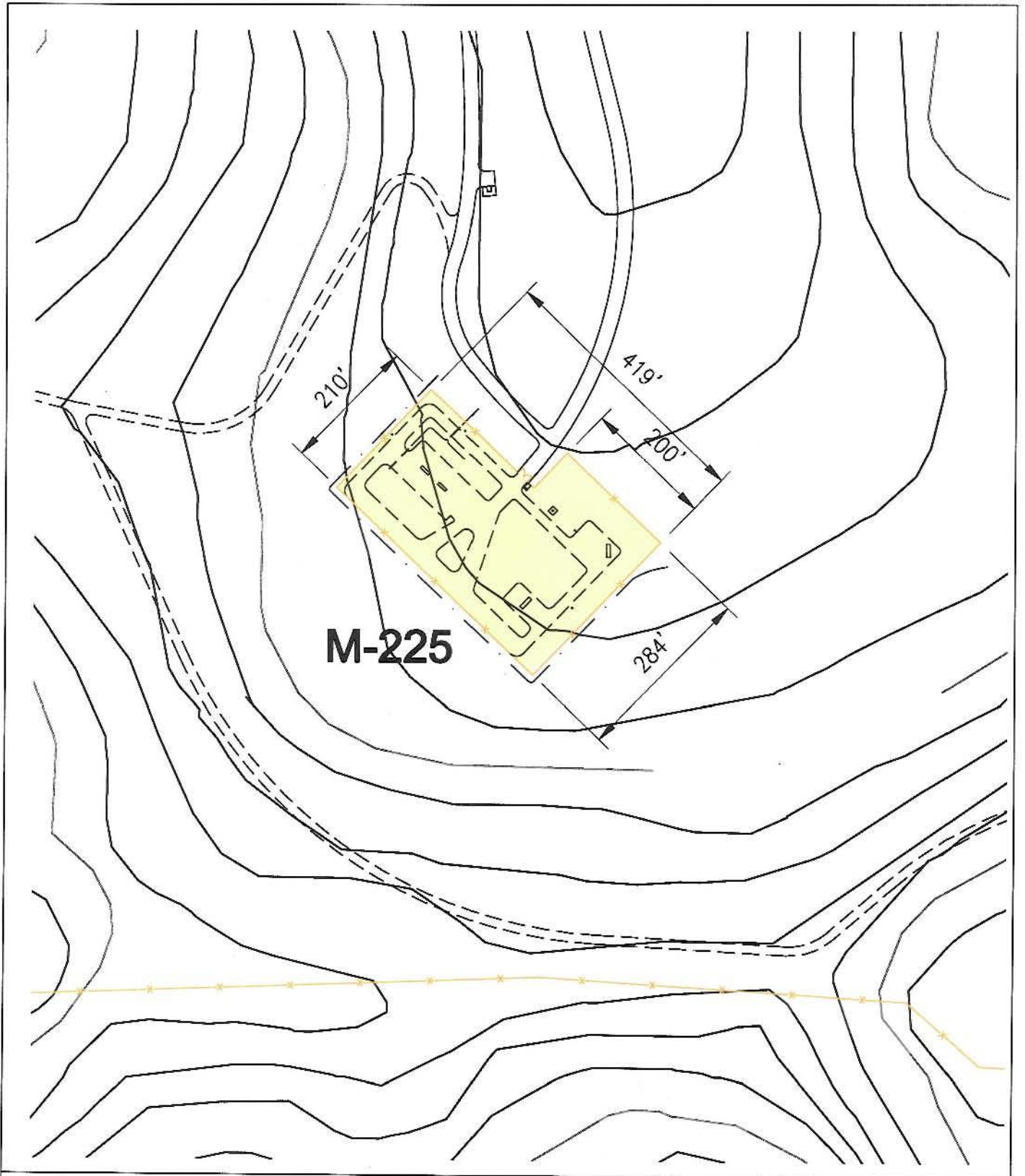
T-29B BUILDING LAYOUT

FIGURE H-1





Figure 6I



M-225

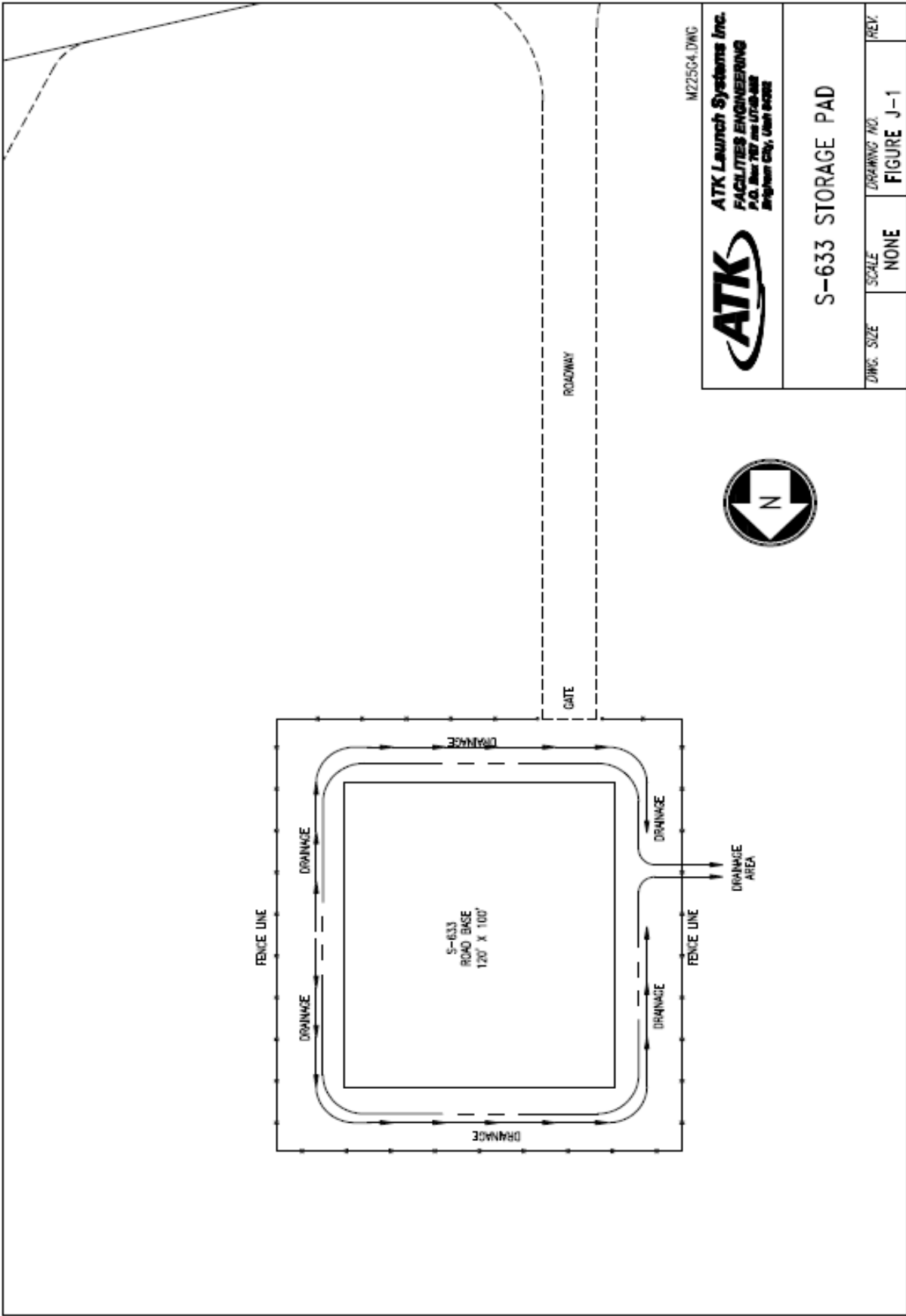
**M-225 BURN GROUND
FACILITY LAYOUT
FIGURE I-1**



SCALE: 1" = 200' - 0"±



Figure 6J



MZ25G4.DWG



ATK Launch Systems Inc.
FACILITIES ENGINEERING
 P.O. Box 702, 101-102
 Brighton City, Utah 84302

S-633 STORAGE PAD

DWG. SIZE	SCALE	DRAWING NO.	REV.
	NONE	FIGURE J-1	